

- Page 1  
Section  
Dimensions  
Car data
- Page 2  
Width  
dimensions
- Page 3  
Approach  
Load plan  
Installation
- Page 4  
Electrical  
installation  
Technical  
data
- Page 5  
To be performed by the customer  
Description

## Stack Parker G61

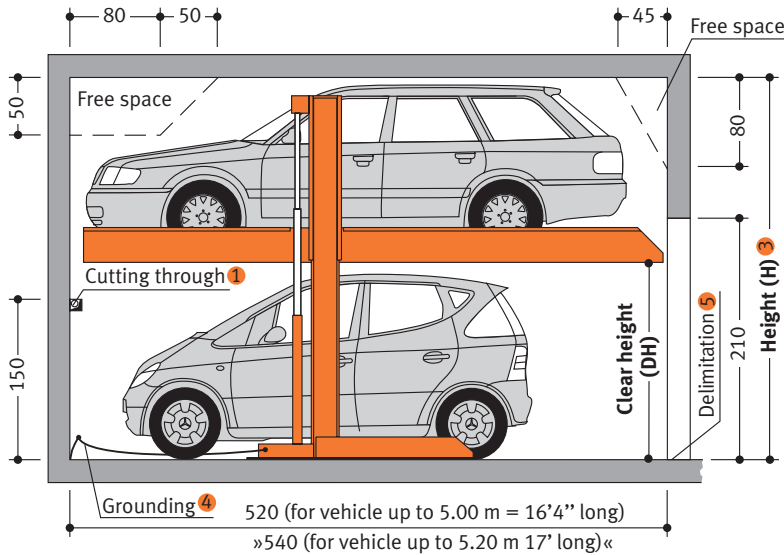

Before lowering the platform, the vehicle parked in the lower parking space must be driven off!

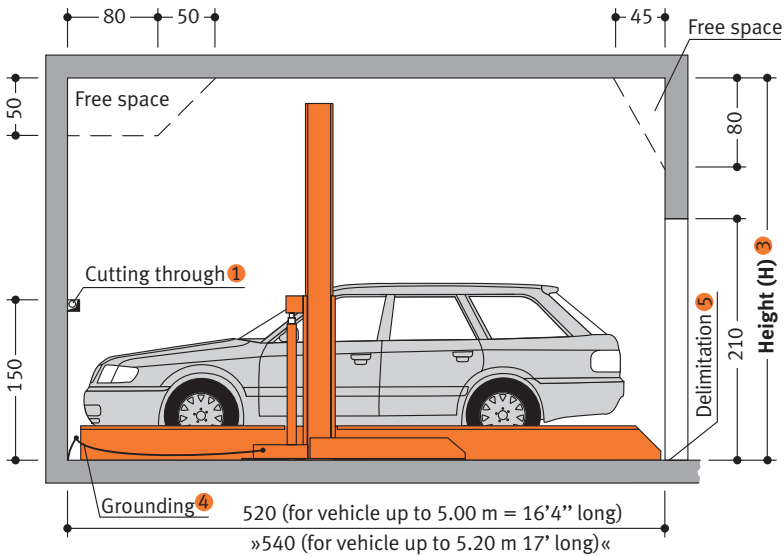

### Garage with door in front of the car parking system

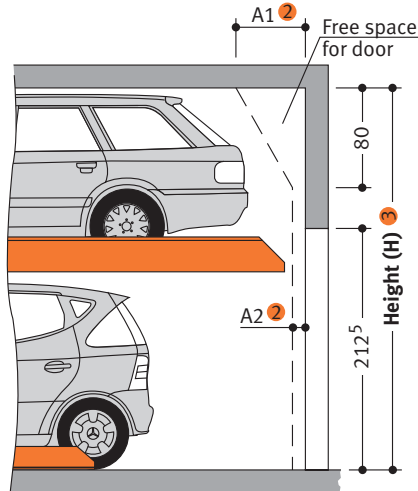

### Notes

- 1 For dividing walls: cutting through 10 x 10 cm (for pipes).
- 2 Dimensions A1, A2 and A3 must be coordinated with the door supplier.
- 3 If the total height is greater, the max. vehicle height for the upper parking space increases accordingly.
- 4 Potential equalization from foundation grounding connection to system.
- 5 In compliance with DIN EN 14 010, 10 cm wide yellow-black markings compliant to ISO 3864 must be applied by the customer to the edge of the platform in the access area to mark the danger zone in front of the supporting surface of the upper platform edge (see »Load Plan«, Page 3)

## Product Data Stack Parker G61



### Dimensions:

All space requirements are minimum finished dimensions. Tolerances for space requirements  $+3_0$ . Dimensions in cm.  
EB (single platform) = 2 vehicles

Type	H	DH**
G61-160	320	160
G61-170*	330	170
G61-180	340	180
G61-190	350	190
G61-200	360	200
G61-210	370	210

\* = standard type    \*\* = without car

### Suitable for:

Standard passenger car and station wagon. Height and length according to contour.

Type	H	car height	
		upper	lower
G61-160	320	150	150
G61-170*	330	150	160
G61-180	340	150	170
G61-190	350	150	180
G61-200	360	150	190
G61-210	370	150	200

\* = standard type

<b>width</b>	<b>1.90 m</b>
<b>weight</b>	<b>max. 2000 kg</b>
<b>wheel load</b>	<b>max. 500 kg</b>

### Standard passenger car

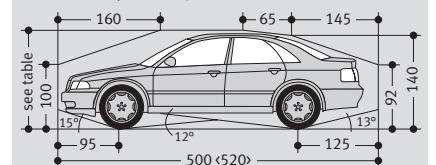

### Standard station wagon

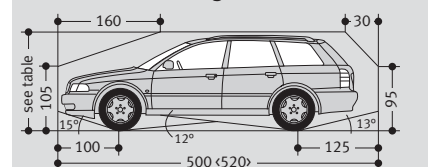

Standard passenger cars are vehicles without any sports options such as spoilers, low-profile tyres etc.



**Klaus Multiparking GmbH**  
Hermann-Krum-Straße 2  
D-88319 Aitrach  
Phone +49-75 65-5 08-0  
Fax +49-75 65-5 08-88  
E-Mail [info@multiparking.com](mailto:info@multiparking.com)  
Internet [www.multiparking.com](http://www.multiparking.com)

Page 1  
Section  
Dimensions  
Car data

Page 2  
Width  
Dimensions

Page 3  
Approach  
Load plan  
Installation

Page 4  
Electrical  
installation  
Technical  
data

Page 5  
To be performed  
by the customer  
Description

## Width for basement garage

### Dividing walls

Single Platform (EB)

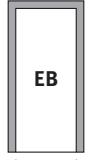

usable platform width	B1
230 *	260
240	270
250	280

Double arrangement (2 x EB)

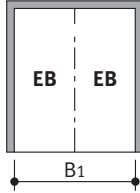

usable platform width	B1
230 *	520
240	540
250	560

Tripple arrangement (3 x EB)

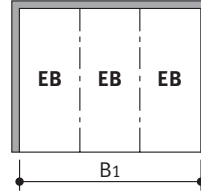

usable platform width	B1
230 *	780
240	810
250	840

Carriageway in accordance with local regulations

### Columns in system zone

Single Platform (EB)

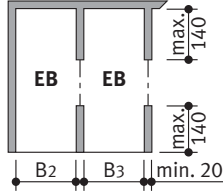

usable platform width	B2	B3
230 *	255	250
240	265	260
250	275	270

Double arrangement (2 x EB)

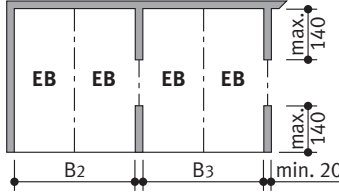

usable platform width	B2	B3
230 *	515	510
240	535	530
250	555	550

Tripple arrangement (3 x EB)

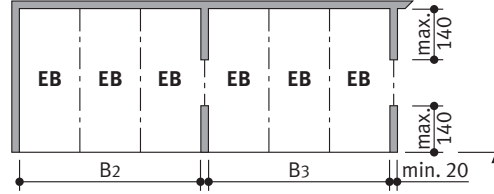

usable platform width	B2	B3
230 *	775	770
240	805	800
250	835	830

Carriageway in accordance with local regulations

### Columns outside of system zone

Single Platform (EB)

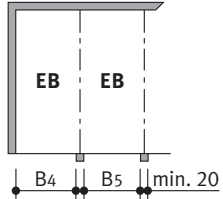

usable platform width	B4	B5
230 *	250	240
240	260	250
250	270	260

Double arrangement (2 x EB)

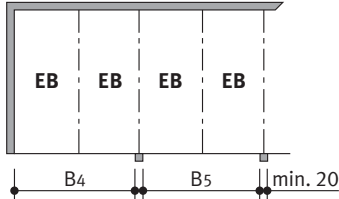

usable platform width	B4	B5
230 *	510	500
240	530	520
250	550	540

Tripple arrangement (3 x EB)

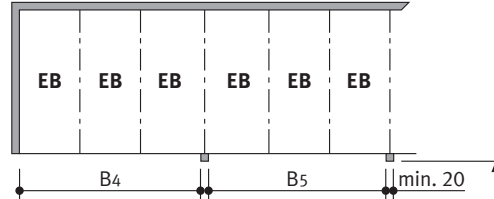

usable platform width	B4	B5
230 *	770	760
240	800	790
250	830	820

Carriageway in accordance with local regulations

## Widths for garage with door in front of car parking system

Single platform (EB)

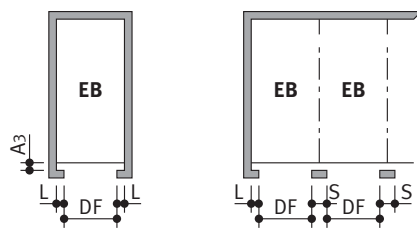

usable platform width	door entrance width DF	L	S
230 *	237 <sup>5</sup>	12 <sup>5</sup>	25
240	250	12 <sup>5</sup>	25
250	250	15	30

A3 = seat-engaging surface (dimensions require coordination with door supplier.)

Allround door dimensions require coordination between door supplier and local agency of Klaus Multiparking.

Double arrangement (DB)

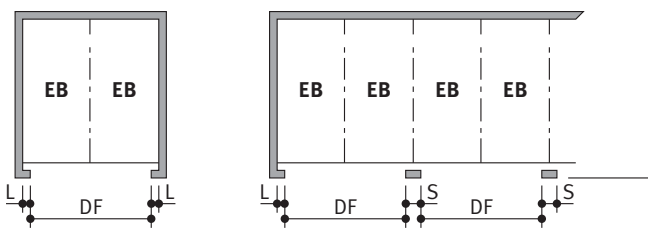

usable platform width	door entrance width DF	L	S
230 *	475	22 <sup>5</sup>	45
240	500	20	40
250	520 <sup>1</sup>	20	40

Carriageway in accordance with local regulations

\* = standard width (parking space width 2.30 m)

<sup>1</sup> = no standard width for doors!

### Please note:



End parking spaces are generally more difficult to drive into. Therefore we recommended for end parking spaces our wider platforms. Parking on standard width platforms with larger vehicles may make getting into and out of the vehicle difficult. This depends on type of vehicle, approach and above all on the individual driver's skill.

- Page 1  
Section  
Dimensions  
Car data
- Page 2  
Width  
dimensions
- Page 3  
Approach  
Load plan  
Installation
- Page 4  
Electrical  
installation  
Technical  
data
- Page 5  
To be performed by the  
customer  
Description

## Approach

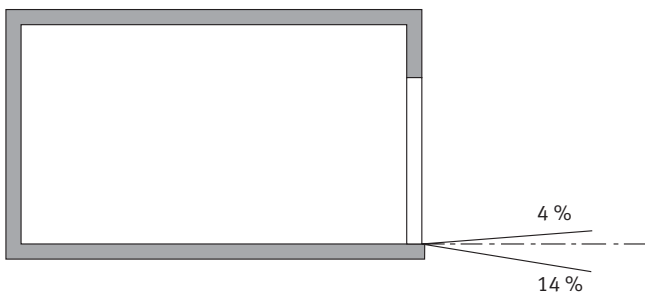

**!** The illustrated maximum approach angles must not be exceeded. Incorrect approach angles will cause serious manoeuvring & positioning problems on the parking system for which the local agency of Klaus accepts no responsibility.

## Load plan

Forces in kN

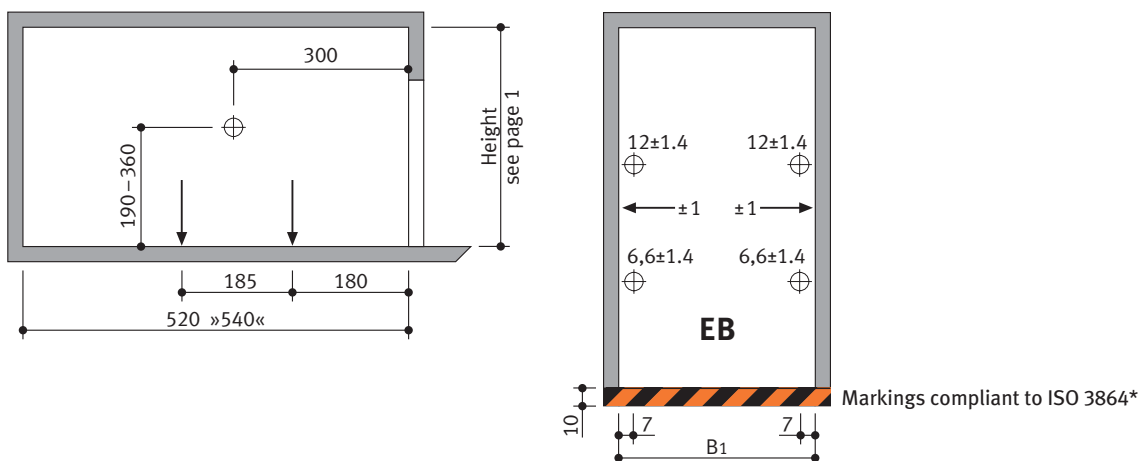

**!** Units are dowelled to the floor. Drilling depth: approx. 15 cm.  
Floor and walls are to be made of concrete (quality minimum C20/25)!

\* = Colors used in this illustration are not ISO 3864 compliant

## Installation data

Free space for longitudinal and vertical ducts (e.g. ventilation)

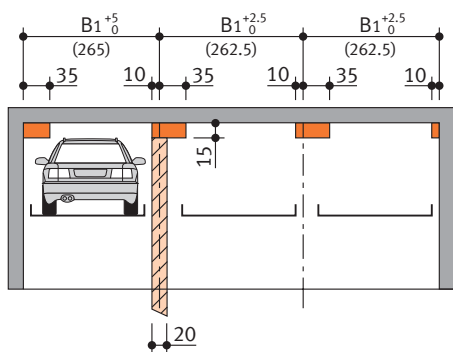

B<sub>1</sub>, B<sub>2</sub> = (see table on page 2)

Free space for vertical pipelines, ventilation branch canals

Free space for horizontal ducting

Approach level

Free space only applicable if vehicle is parked forwards = FRONT FIRST and driver's door on the left side.

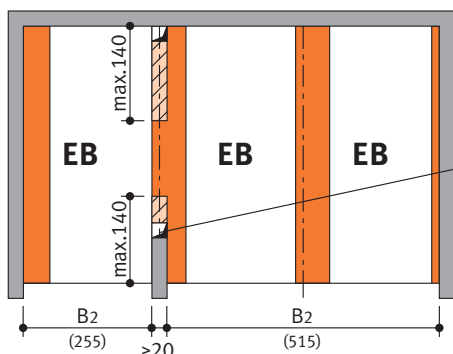

( ) = Dimensions in brackets illustrate an example for usable platform width 230 cm.

Example for ventilation branch canal and/or vertical pipelines.

Page 1  
Section  
Dimensions  
Car data

Page 2  
Width  
Dimensions

Page 3  
Approach  
Load plan  
Installation

Page 4  
Electrical  
Installation  
Technical  
data

Page 5  
To be performed by the customer  
Description

## Electrical installation

### Installation diagram

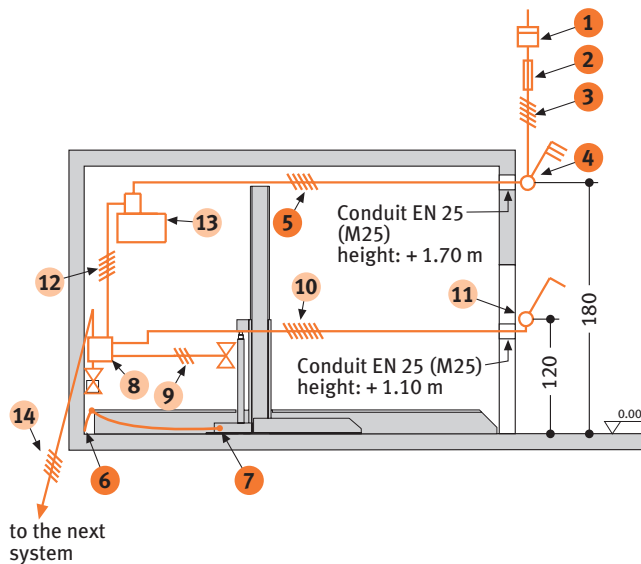

### Electrical data (to be performed by the customer)

No.	Quantity	Description	Position	Frequency
1	1	Electricity meter	in the supply line	
2	1	Main fuse: 3 x fuse 16 A (slow) or circuit breaker 3 x 16 A (trigger characteristic K, G or C)	in the supply line	1 per unit
3	1	Supply line 5 x 2.5 mm <sup>2</sup> (3 PH + N + PE) with marked wire and protective conductor	to main switch	1 per unit
4	1	Lockable main switch	defined at the plan evaluation	1 per unit
5	1	Supply line 5 x 2.5 mm <sup>2</sup> (3 PH + N + PE) with marked wire and protective conductor	from main switch to unit	1 per unit
6	every 10 m	Foundation earth connector	corner pit floor	
7	1	Equipotential bonding in accordance with DIN EN 60204 from foundation earth connector to the system		1 per system

### Electrical data (included in delivery of Klaus Multiparking)

No.	Description
8	Terminal box
9	Control line 3 x 0.75 mm <sup>2</sup> (PH + N + PE)
10	Control line 7 x 1.5 mm <sup>2</sup> with marked wire and protective conductor
11	Operating device
12	Control line 5 x 1.5 mm <sup>2</sup> with marked wire and protective conductor
13	Hydraulic unit 3.0 kW, three-phase current, 400 V / 50 Hz
14	Control line 5 x 1.5 mm <sup>2</sup> with marked wire and protective conductor

## Technical data

### Range of application

Generally, this parking system is not suited for short-time parkers (temporary parkers). Please do not hesitate to contact your local KLAUS agency for further assistance.

### Units

Low-noise power units mounted to rubber-bonded-to metal mountings are installed. Nevertheless we recommend that parking system's garage be built separately from the dwelling.

### Available documents

- wall recess plans
- maintenance offer/contract
- declaration of conformity
- test sheet on airborne and slid-borne sound

### Corrosion protection

See separate sheet regarding corrosion protection.

### Railings

If there are traffic routes next to or behind the installations, railings compliant to DIN EN 294 must be installed by the customer. Railings must also be in place during construction.

### Environmental conditions

Environmental conditions for the area of multiparking systems: Temperature range -10 to +40° C. Relative humidity 50% at a maximum outside temperature of +40° C. If lifting or lowering times are specified, they refer to an environmental temperature of +10° C and with the system set up directly next to the hydraulic unit. At lower temperatures or with longer hydraulic lines, these times increase.

### Sound insulation

According to DIN 4109 (Sound insulation in buildings), para. 4, annotation 4, Klaus Multiparkers are part of the building services (garage systems).

#### Normal sound insulation:

DIN 4109, para. 4, Sound insulation against noises from building services.

Table 4 in para. 4.1 contains the permissible sound level values emitted from building services for personal living and working areas. According to line 2 the maximum sound level in personal living and working areas must not exceed 30 dB (A).

*Noises created by users are not subject to the requirements (see table 4, DIN 4109).*

The following measures are to be taken to comply with this value:

- Sound protection package according to offer/order (Klaus Multiparking GmbH)
- Minimum sound insulation of building  $R'_w = 57$  dB (to be provided by customer)

#### Increased sound insulation (special agreement):

DIN 4109, Amendment 4, Information on planning and execution, proposals for increased sound insulation.

Agreement: Maximum sound level in personal living and working areas 25 dB (A). *Noises created by users are not subject to the requirements (see table 4, DIN 4109).*

The following measures are to be taken to comply with this value:

- Sound protection package according to offer/order (Klaus Multiparking GmbH)
- Minimum sound insulation of building  $R'_w = 62$  dB (to be provided by customer)

Note: User noises are noises created by individual users in our Multiparking systems. These can be noises from accessing the platforms, slamming of vehicle doors, motor and brake noises.

Page 1  
Section  
Dimensions  
Car data

Page 2  
Width  
Dimensions

Page 3  
Approach  
Load plan  
Installation

Page 4  
Electrical  
Installation  
Technical  
data

Page 5  
To be performed by the customer  
Description

## To be performed by the customer

### Safety fences

Any constraints that may be necessary according to DIN EN 294 in order to provide protection, for pathways directly in front, next to or behind the unit. This is also valid during construction.

### Numbering of parking spaces

Consecutive numbering of parking spaces.

### Building services

Lighting, ventilation, fire extinguishing and fire alarm systems.

### Marking

According to DIN EN 14 010, a warning that identifies this danger area must be placed in the entrance area that conforms to ISO 3864. This must be done according to EN 92/58/EWG for systems without a pit 10 cm from the edge of the platform.

### Wall cuttings

Any necessary wall cuttings according to page 1.

### Electrical supply to the main switch

Suitable electrical supply to the main switch and the control wire line must be provided by the customer during installation. The functionality can be monitored on site by our fitters together with the electrician. If this cannot be done during installation for some reason for which the customer is responsible, the customer must commission an electrician at their own expense and risk.

### Operating device

Cable conduits and recesses for operating device (for double wing doors: please contact the local agency of Klaus Multiparking).

#### Operating device exposed

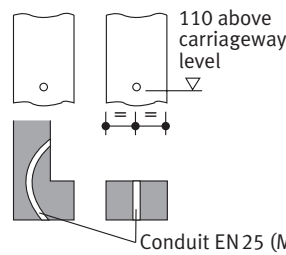

#### Operating device concealed

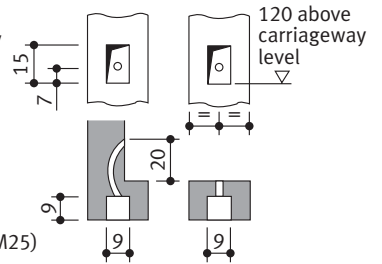

If the following are not included in the quotation, they will also have to be provided / paid for by the customer:

- Mounting of contactor and terminal box to the wall valve, complete wiring of all elements in accordance with the circuit diagram
- Costs for final technical approval by an authorized body

## Description

### General description

Multiparking system providing dependent parking spaces for 2 cars one on top of the other each. The lower vehicle parks directly on the floor plate. The vehicle parked on the bottom must be driven out before lowering the platform.

Dimensions are in accordance with the underlying dimensions of parking pit, height and width

The parking bays are accessed horizontally (installation deviation  $\pm 1\%$ ).

Vehicles are positioned on the upper parking space using wheel stops on the right side (adjust according to operating instructions).

Operation via operating device with hold-to-run-device using master keys.

The operating elements are usually mounted either in front of the column or on the outside of the door frame

Operating instructions are attached to each operator's stand.

For garages with doors at the front of the parking system the special dimensional requirements have to be taken into account.

### Multiparking system consisting of:

- 2 steel pillars with base plates (mounted on the floor)
- 2 sliding platforms (mounted to the steel pillars with sliding bearings)
- 1 platform
- 1 mechanic synchronization control system (to ensure synchronous operation of the hydraulic cylinders while lowering and lifting the platform)
- 1 hydraulic cylinder
- 1 automatic hydraulic safety valve (prevents accidental lowering of the platform while accessing the platform)
- Dowels, screws, connecting elements, bolts, etc.
- The platforms and parking spaces are end-to-end accessible for parking!

### Platforms consisting of:

- Platform base sections
- Adjustable wheel stops
- Canted access plates
- Side members
- Cross members
- Screws, nuts, washers, distance tubes, etc.

### Hydraulic system consisting of:

- Hydraulic cylinder
- Solenoid valve
- Safety valve
- Hydraulic conduits
- Screwed joints
- High-pressure hoses
- Installation material

### Electric system consisting of:

- Operating device (Emergency Stop, lock, 1 master key per parking space)
- Terminal box at wall valve
- Electrical locking device

### Hydraulic unit consisting of:

- Hydraulic power unit (low-noise, installed onto a console with a rubber-bonded-to-metal mounting)
- Hydraulic oil reservoir
- Oil filling
- Internal geared wheel pump
- Pump holder
- Clutch
- 3-phase-AC-motor (3.0 kW, 230/400 V, 50 Hz)
- Contactor (with thermal overcurrent relay and control fuse)
- Test manometer
- Pressure relief valve
- Hydraulic hoses (which reduce noise transmission onto the hydraulic pipe)

## We reserve the right to change this specification without further notice

The Klaus company reserves the right in the course of technical progress to use newer or other technologies, systems, processes, procedures or standards in the fulfillment of their obligations other than those originally offered provided the customer derives no disadvantage from their so doing.