

- Page 1  
Section  
Dimensions  
Car data
- Page 2  
Width  
dimensions
- Page 3  
Approach  
Load plan  
Free spaces  
Function
- Page 4  
Electric data  
Techn. data  
To be performed  
by the customer
- Page 5  
Description

### Standard Type P310-2,0/175/345

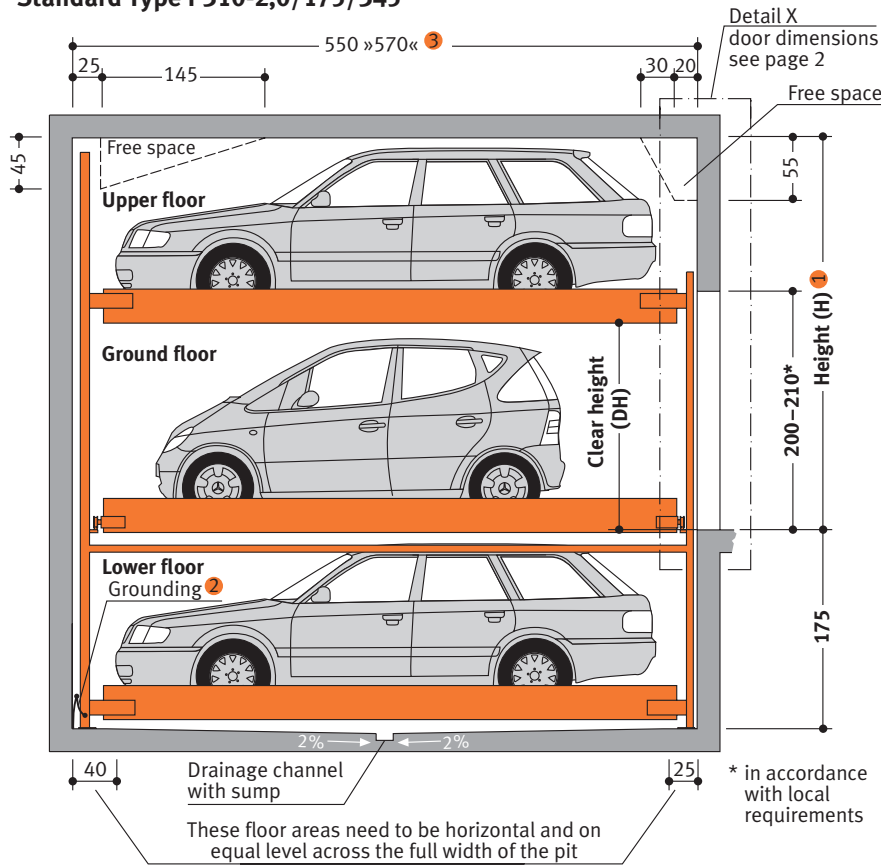

### Exklusive Type P310-2,0/200/405

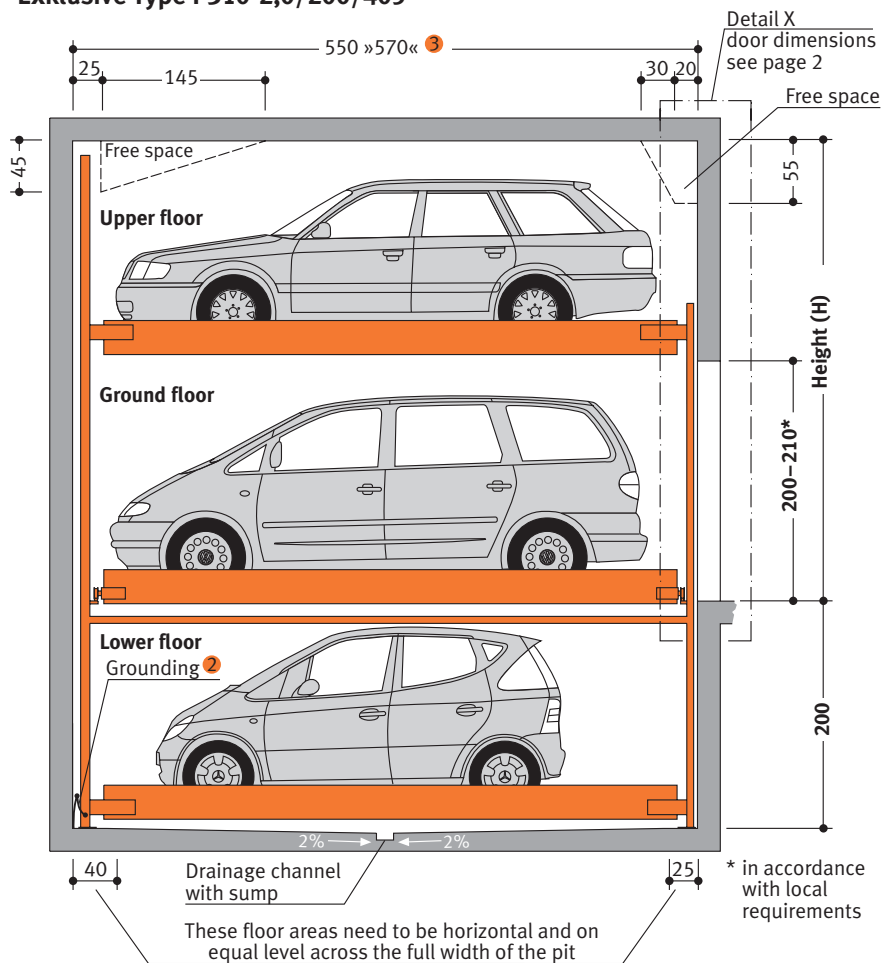

#### Notes

- 1 If height H is larger, higher vehicles up to 185 cm maximum can be parked in the upper floor, or there is corresponding clearance on the ceiling.
- 2 If height H is larger, higher vehicles up to 205 cm maximum can be parked in the upper floor, or there is corresponding clearance on the ceiling.
- 3 Special model for cars up to a length of 5.20 m: total length 5.70 m.
- 4 Potential equalization from foundation grounding connection to system.

## Product Data

# Parking Automat

# P310-2,0



**Number of parking spaces:**  
min. 5 to max. 29 vehicles

**Dimensions:**  
All space requirements are minimum finished dimensions. Tolerances for space requirements  $+3_0$ . Dimensions in cm.

Type	H	DH**
P310-2,0/175/345*	345	175
P310-2,0/200/405	405	210

\* = standard type    \*\* = without car

**Suitable for:**  
Standard passenger car, station wagon/  
Van. Height and length according  
to contour.

Type	car height		
	upper floor	ground floor	lower floor
P310-2,0/175/345*	150	170	150
P310-2,0/200/405	175	205	175

\* = Standardtyp

<b>width</b>	1.90 m
<b>weight</b>	max. 2000 kg
<b>wheel load</b>	max. 500 kg

#### Standard passenger car

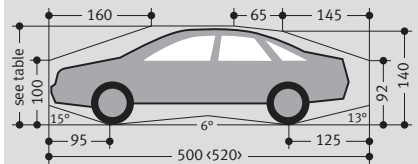

#### Standard station wagon/Van

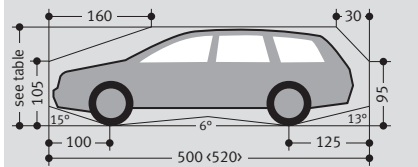

Standard passenger cars are vehicles without any sports options such as spoilers, low-profile tyres etc.



**Klaus Multiparking GmbH**  
Hermann-Krum-Straße 2  
D-88319 Aitrach  
Phone +49-75 65-5 08-0  
Fax +49-75 65-5 08-88  
E-Mail [info@multiparking.com](mailto:info@multiparking.com)  
Internet [www.multiparking.com](http://www.multiparking.com)

Page 1  
Section  
Dimensions  
Car data

Page 2  
Width  
dimensions

Page 3  
Approach  
Load plan  
Free spaces  
Function

Page 4  
Electric data  
Techn. data  
To be performed  
by the  
customer

Page 5  
Description

## Widths – Detail X for garages with sliding doors (Standard)

### Sliding door behind columns

Columns per each grid unit (S = 20)

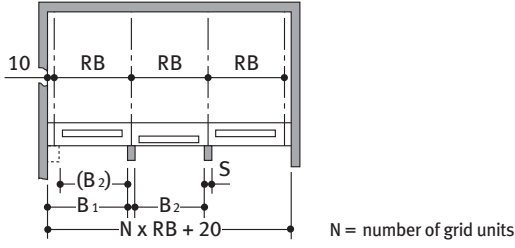

usable platform width	Grid unit width RB**	B1	B2
230 *	250	250	230
240	260	260	240
250	270	270	250
260	280	280	260
270	290	290	270

Columns every second grid unit (S = 20)

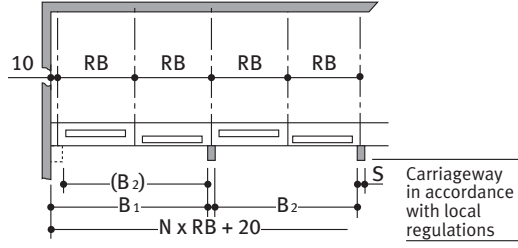

usable platform width	Grid unit width RB**	B1	B2
230 *	250	500	480
240	260	520	500
250	270	540	520
260	280	560	540
270	290	580	560

Detail X

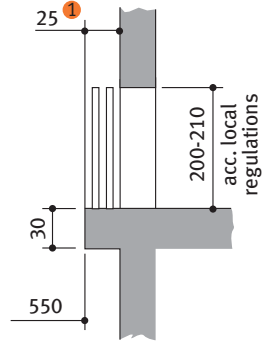

### Sliding door between columns

Columns per each grid unit

Not available!

Columns every second grid unit (S = 20)

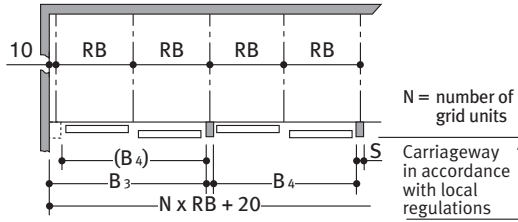

usable platform width	Grid unit width RB**	B3	B4
230 *	250	500	480
240	260	520	500
250	270	540	520
260	280	560	540
270	290	580	560

Detail X

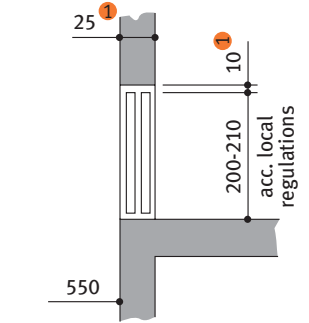

### Sliding door in front of columns

Columns per each grid unit (S = 20)

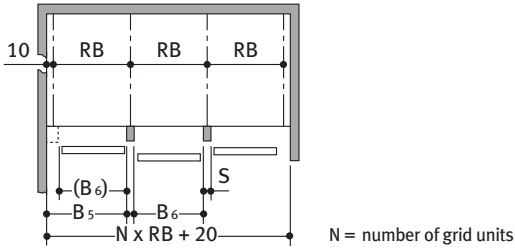

usable platform width	Grid unit width RB**	B5	B6
230 *	250	250	230
240	260	260	240
250	270	270	250
260	280	280	260
270	290	290	270

Columns every second grid unit (S = 20)

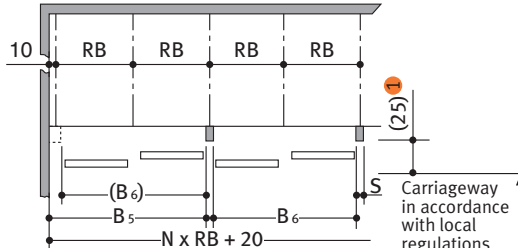

usable platform width	Grid unit width RB**	B5	B6
230 *	250	500	480
240	260	520	500
250	270	540	520
260	280	560	540
270	290	580	560

Detail X

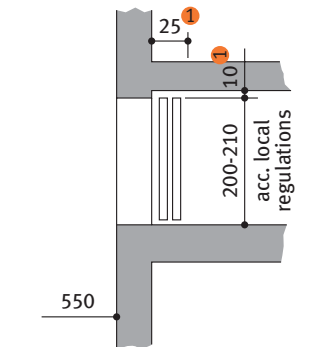

## Widths – Detail X for garages with roll doors

### Roll door behind columns

Columns per each grid unit

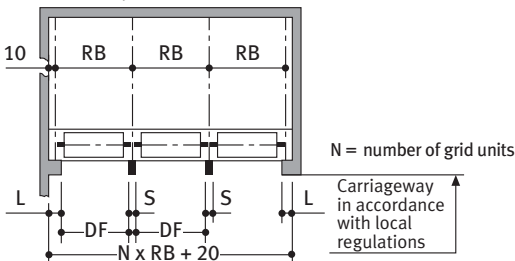

usable platform width	Grid unit width RB**	Door entrance width DF	L	S
230 *	250	230	20	20
240	260	240	20	20
250	270	250	20	20
260	280	260	20	20
270	290	270	20	20

Detail X

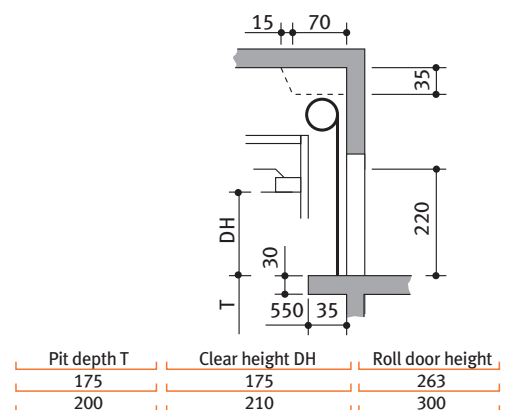

\* = Standard width (parking space width 2,30 m)  
\*\* = Grid unit width must strictly conform to dimensions quoted!

① = Only applies to manually operated doors.  
The electrically driven doors must have the following dimensions: 10 > 20 and 25 > 35!

! End parking spaces are generally more difficult to drive into. Therefore we recommended for end parking spaces our wider platforms. Parking on standard width platforms with larger vehicles may make getting into and out of the vehicle difficult. This depends on type of vehicle, approach and above all on the individual driver's skill.

Page 1  
Section  
Dimensions  
Car data

Page 2  
Width  
Dimensions

Page 3  
Approach  
Load plan  
Free spaces  
Function

Page 4  
Electric data  
Techn. data  
To be performed  
by the customer

Page 5  
Description

## Approach

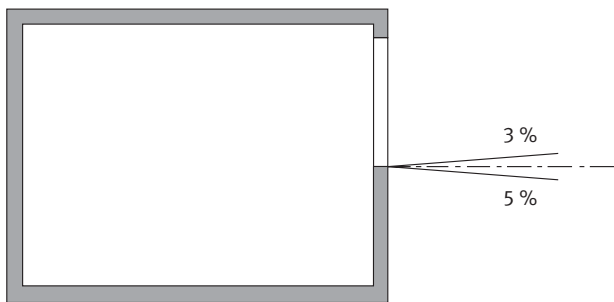

**!** The illustrated maximum approach angles must not be exceeded. Incorrect approach angles will cause serious manoeuvring & positioning problems on the parking system for which the local agency of Klaus accepts no responsibility.

## Load plan

Forces in kN

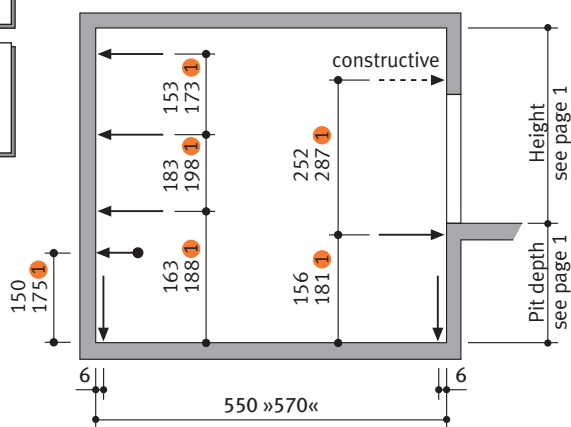

① = Dimensions for Exclusive Type

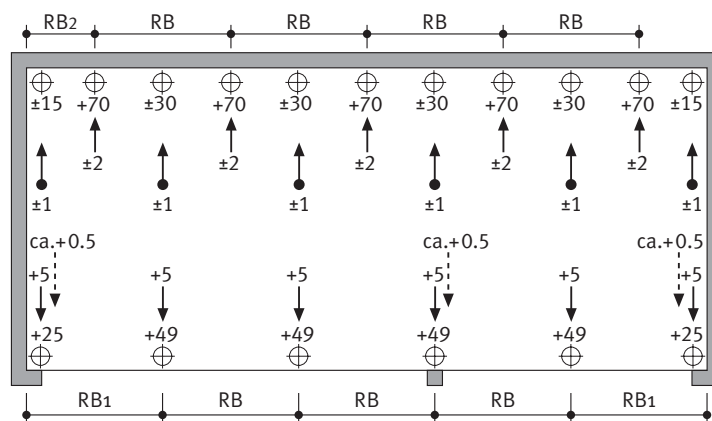

usable platform width	RB	RB1	RB2
230*	250	260	135
240	260	270	140
250	270	280	145
260	280	290	150
270	290	300	155

**!** The system is dowelled to floor and walls. The drilling depth in the floor is approx. 15 cm. The drilling depth in the walls is approx. 12 cm. Floor and walls are to be made of concrete (grade of concrete min. C20/25)!

## Longitudinal free space; Standard parking space numbers; Denomination

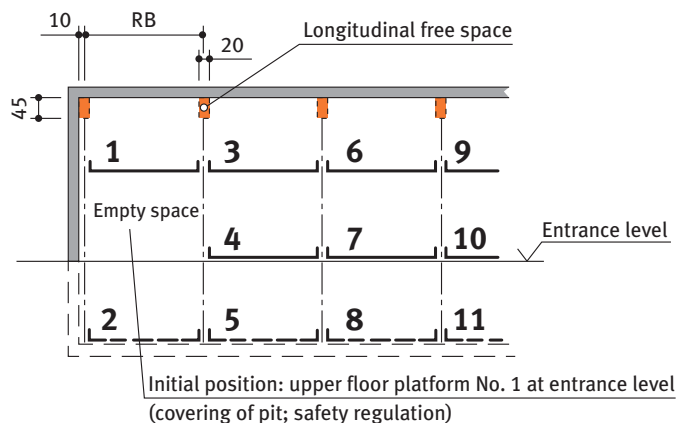

### Moving direction

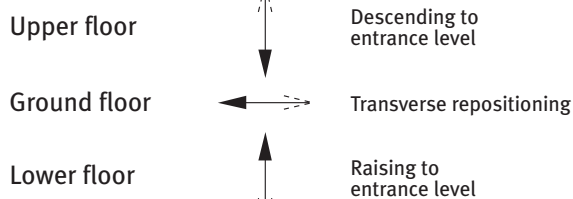

## Function of the Parking Automat

e.g. for parking space No. 8:  
Check first that all doors are closed, then select No. 8 on operating panel.

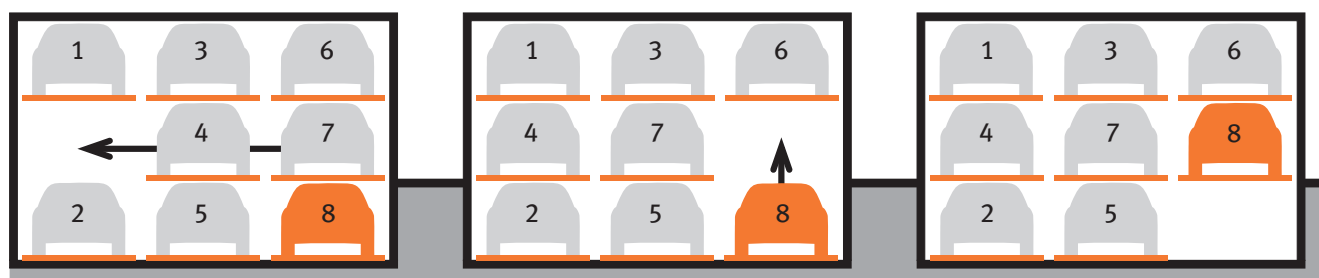

For driving the vehicle off platform No. 8 the ground floor parking platforms are shifted to the left.

The empty space is now below the vehicle which shall be driven off the platform. The platform No. 8 will be lowered.

The vehicle on platform No. 8 can now be driven off the platform.

Page 1  
Section  
Dimensions  
Car data

Page 2  
Width  
Dimensions

Page 3  
Approach  
Load plan  
Free spaces  
Function

Page 4  
Electric data  
Techn. data  
To be performed  
by the customer

Page 5  
Description

## Electrical data

### Control box

The control box must be accessible at all times from outside!

Dimensions approx. 100 x 100 x 30 cm.

Cutting through of wall from control box to parking system (contact the local agency of Klaus Multiparking for clarification)

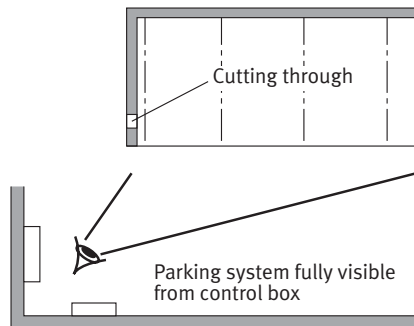

### Electrical supply

Suitable electrical supply 5 x 2.5 mm<sup>2</sup> (3 PH+N+PE) to control box with mains fuse 3 x 16 A slow or over-current cut-out 3 x 16 A trigger characteristic K or C.

Suitable electrical supply to the control box must be provided by the customer during installation. The functionality can be monitored on site by our fitters together with the electrician. If this cannot be done during installation for some reason for which the customer is responsible, the customer must commission an electrician at their own expense and risk.

### Foundation earth connector

In accordance with DIN EN 60204 (Safety of Machinery. Electrical Equipment), the system must be connected to a foundation earth. A foundation earth connection must be installed at intervals of 10 m.

### Operating device

Easy-to-survey positioning (e.g. on column).

Protection against unauthorized use.

May also be recessed in wall if required.

## Technical data

### Range of application

Generally, this parking system is not suited for short-time parkers (temporary parkers). Please do not hesitate to contact your local KLAUS agency for further assistance.

### Available documents

- wall recess plans
- maintenance offer/contract
- declaration of conformity
- test sheet on airborne and slid-borne sound

### Corrosion protection

See separate sheet regarding corrosion protection.

### Environmental conditions

Environmental conditions for the area of multiparking systems: Temperature range –10 to +40 °C. Relative humidity 50 % at a maximum outside temperature of +40 °C.

If lifting or lowering times are specified, they refer to an environmental temperature of +10 °C and with the system set up directly next to the hydraulic unit. At lower temperatures or with longer hydraulic lines, these times increase.

### Electrically driven doors

In accordance with ZH 1/494 commercially used power-driven doors must be subjected to annual inspections. We urgently recommend concluding a maintenance agreement that includes this service for the entire system.

### Numbering

The standard numbering of the parking spaces is to be taken from page 3. Different numbering is only possible at extra cost. Please take note of the following specifications:

In general, the empty space must be arranged to the left. The numbers must be provided 8 – 10 weeks before the delivery date.

### Sound insulation

According to DIN 4109 (Sound insulation in buildings), para. 4, annotation 4, Klaus Multiparkers are part of the building services (garage systems).

#### Normal sound insulation:

DIN 4109, para. 4, Sound insulation against noises from building services.

Table 4 in para. 4.1 contains the permissible sound level values emitted from building services for personal living and working areas. According to line 2 the maximum sound level in personal living and working areas must not exceed 30 dB (A).

*Noises created by users are not subject to the requirements (see table 4, DIN 4109).*

The following measures are to be taken to comply with this value:

- Sound protection package according to offer/order (Klaus Multiparking GmbH)
- Minimum sound insulation of building  $R'_w = 57$  dB (to be provided by customer)

#### Increased sound insulation (special agreement):

DIN 4109, Amendment 2, Information on planning and execution, proposals for increased sound insulation.

Agreement: Maximum sound level in personal living and working areas 25 dB (A). *Noises created by users are not subject to the requirements (see table 4, DIN 4109).*

The following measures are to be taken to comply with this value:

- Sound protection package according to offer/order (Klaus Multiparking GmbH)
- Minimum sound insulation of building  $R'_w = 62$  dB (to be provided by customer)

Note: User noises are noises created by individual users in our Multiparking systems. These can be noises from accessing the platforms, slamming of vehicle doors, motor and brake noises.

## To be performed by the customer

### Safety fences

Any constraints that may be necessary according to DIN EN 294 in order to provide protection for the park pits for pathways directly in front, next to or behind the unit. This is also valid during construction.

### Numbering of parking spaces

Consecutive numbering of parking spaces.

### Building services

Lighting, ventilation, fire extinguishing and fire alarm systems.

### Drainage

For the middle area of the pit we recommend a drainage channel, which you connect to a floor drain system or sump (50 x 50 x 20 cm). The drainage channel may be inclined to the side, however not the pit floor itself (longitudinal incline is available). For reasons of environmental protection we recommend to paint the pit floor, and to provide oil and petrol separators in the connections to the public sewage network.

### Strip footings

If due to structural conditions strip footings must be effected, the customer shall provide an accessible platform reaching to the top of the said strip footings to enable and facilitate themounting work.

### Wall cuttings

Any necessary wall cuttings.

### Electrical supply to the control box

Suitable electrical supply to the control box must be provided by the customer during installation. The functionality can be monitored on site by our fitters together with the electrician. If this cannot be done during installation for some reason for which the customer is responsible, the customer must commission an electrician at their own expense and risk.

### Door shields

Door shields that may be necessary. If desired, they can be ordered from Klaus Multiparking for an additional charge.

### If the following are not included in the quotation, they will also have to be provided / paid for by the customer:

- Costs for final technical approval by an authorized body

Page 1  
Section  
Dimensions  
Car data

Page 2  
Width  
Dimensions

Page 3  
Approach  
Load plan  
Free spaces  
Function

Page 4  
Electric data  
Techn. data  
To be performed  
by the customer

Page 5  
Description

## Description

### General description

Multiparking system providing independent parking spaces for cars, one on top of the other and side by side.

Dimensions are in accordance with the underlying dimensions of parking pit, height and width

The parking bays are accessed horizontally (installation deviation  $\pm 1\%$ ).

Along the complete width of the parking automat an approach lane (driving lane in accordance with local regulations) must be available.

Parking spaces are arranged on three different levels, one level on top of the other

The platforms of both the lower floor (LF) and upper floor (UF) are moved vertically, the platforms of the ground floor (GF) horizontally. At approach level (GF) there is always one parking space less available. This vacant space is used for shifting the ground floor (GF) parking spaces sideways, thus enabling an upper floor (UF) parking space or lower floor (LF) parking space to be lowered or lifted to approach level. Consequently, a unit of five parking spaces (2 on the upper floor, 1 on the ground floor, 2 on the lower floor) is the smallest unit available for this parking system.

The parking automat P310 allows parking of passenger cars and station wagons.

For safety reasons the platforms can only be moved behind electromagnetically locked doors.

All necessary safety devices are installed. This consists mainly of a chain monitoring system, locking lever for the upper and lower platforms and electromagnetic door locks.

The doors can only be opened if the selected parking space has reached the park position and all openings are secured.

### A steel framework mounted inside the pit, consisting of

- Seriated supports
- Steel pillars with sliding platform supports
- Cross and longitudinal members
- running rails for the transversely movable ground floor (GF) platforms

### Platforms consisting of:

- Side members
- Cross members
- Platform base sections
- 1 wheel stop (on the right per parking space)
- Screws, small parts, etc.

### Lifting device for upper floor (UF) and lower floor (LF) platforms:

- Hydraulic cylinder with solenoid valve
- Chain wheels
- Chains
- Limit switches
- The platforms are suspended on four points and guided along the supports using plastic sliding bearings.

### Drive unit of transversely movable platforms on the ground floor (GF):

- Gear motor with chain wheel
- Chains
- Running and guide rollers (low-noise)
- power supply via cable mast

### Hydraulic unit consisting of:

- Hydraulic power unit (low-noise, installed onto a console with a rubber-bonded-to-metal mounting)
- Hydraulic oil reservoir
- Oil filling
- Cover with integrated internal geared wheel pump
- Pump holder
- Clutch
- 3-phase-AC-motor (3.0 kW, 230/400 V, 50 Hz)
- Motor circuit breaker
- Test manometer
- Pressure relief valve
- Hydraulic hoses (which reduce noise transmission onto the hydraulic pipe)

## We reserve the right to change this specification without further notice

The Klaus company reserves the right in the course of technical progress to use newer or other technologies, systems, processes, procedures or standards in the fulfillment of their obligations other than those originally offered provided the customer derives no disadvantage from their so doing.

### Manually operating sliding doors, which are opened sideways:

Sliding doors, approx 2500 mm x 2000 mm.

### Framework

- Welded framework with one vertical center bar with stop profiles.
- The recessed grip is integrated in a vertical profile.

### Fill

Standard:

- Wire grating, mesh size: 12 mm
- Not suitable for outdoor installations

Alternative:

- Trapezoidal sheet metal fill, thickness: 1 mm. Profile of sheet metal is adjusted to door width
- Wood with vertical profile, Norway spruce, composite slab, thickness: 16 mm, untreated for glazing by customer. Door framework without center bar.
- Fill provided by customer, max. weight: 10 kg/m<sup>2</sup>, max. thickness: 25 mm. Fill must contribute to stabilizing the framework. Door framework without center bar.

### Running rails

- The running construction consists of one door with twin-pair rollers, adjustable in height
- The running rails for the doors are fixed to the either consoles, concrete lintels or a door suspension provided by the customer by using brackets
- Guiding is enabled by 2 plastic rollers on a base plate that is dowelled to the floor

### Door actuation

Standard:

- Manual, i.e., the door is opened and closed by hand

Alternative:

- Electric drive via electromotor that is mounted to the turning point of the sliding doors. The drive pinion engages into a chain mounted to the door.

For safety reasons the platforms are only moved when the doors are locked. The “Door open” and “Door closed” positions are monitored via electric sensors.

### Corrosion protection

Door framework:

- Shot-blasted (purity: SA 2.5), powder-coated (Epoxy / Polyester base) RAL 7040, dry film thickness approx. 60 – 80  $\mu$

Fill (wire grating, trapezoidal plate):

- Shot-blasted (purity: SA 2.5), powder-coated (Epoxy / Polyester base) RAL 7040, dry film thickness approx. 60 – 80  $\mu$

Grating separation, if necessary:

- Framework with wire grating, mesh size: 12 mm, shot-blasted (purity: SA 2.5), powder-coated (Epoxy / Polyester base) RAL 7040, dry film thickness approx. 60 – 80  $\mu$

Running rails, brackets, base plate for guiding rollers:

- Electrogalvanized

### Please note:

Door covers (on the sides to cover the running rails, etc.) and door suspensions are not part of the standard delivery. They can be ordered as special equipment against additional charge.

### Control system:

- Central control panel (operating device) used to select the desired parking space
- With series installation, the doors are opened manually. If desired, this can also be done using electric motors
- Electric wiring is made from the electric cabinet by the manufacturer