

# P310 Parking Automat

## Function of the Parking Automat

(e.g. for retrieving vehicle off platform no.8)

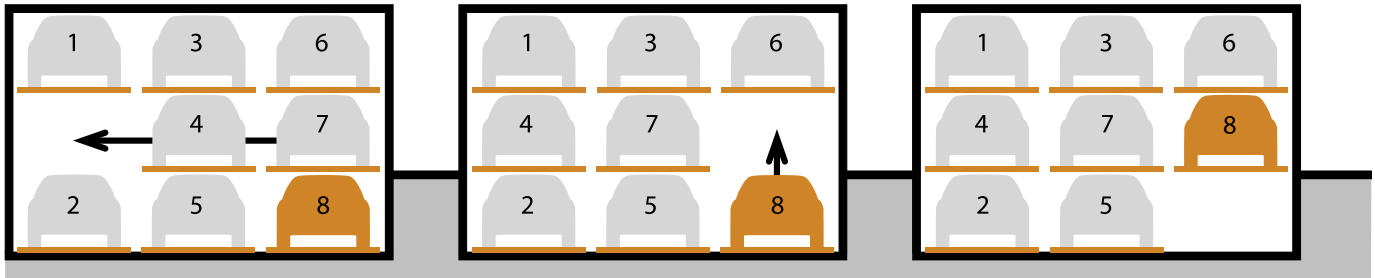

The ground floor parking platforms are shifted to the left.

The empty space is now above the vehicle which shall be driven off the platform. The platform No. 8 will be lifted.

The vehicle on platform No. 8 can now be driven off the platform.

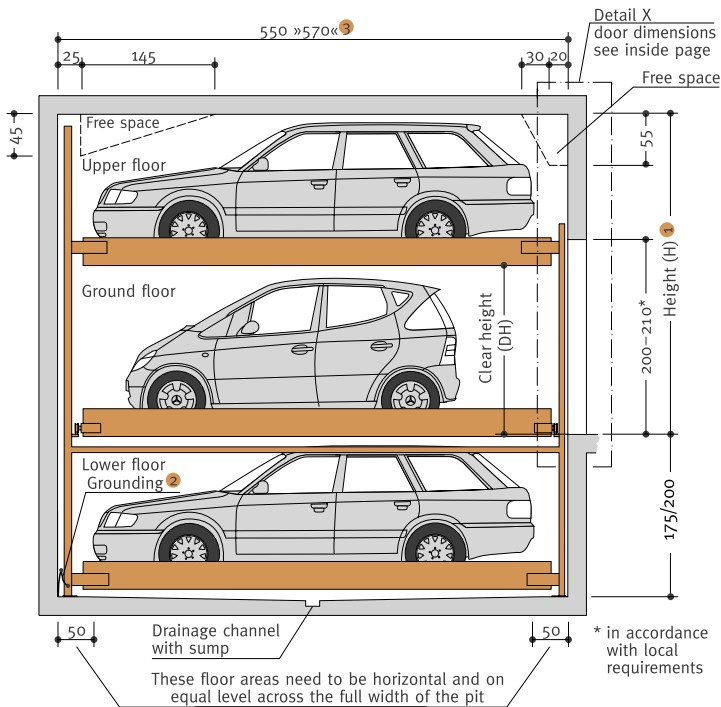

Number of parking spaces:  
min. 5 to max. 29 vehicles

Dimensions: All space requirements are minimum finished dimensions. Tolerances for space requirements

Dimensions in cm. <sup>+3</sup>/<sub>0</sub>

Type	H	DH**
P310-175*	345	175
P310-200	405	210

\*standard type \*\* without car

Suitable for: Standard passenger car and station wagon. Height and length according to contour.

### Car Height

Type	Upper Floor	Ground Floor	Lower Floor
P310-175*	150	170	150
P310-200	175	200	175

\*standard type

width 1,90m  
weight max. 2000kg  
wheel load max. 500kg

- Changes in height H change the car heights on the upper floor or corresponding clearances on the ceiling.
- Potential Equalisation from foundation grounding connecting to the system.
- Special Model: For cars up to a length of 5.20m. Please note: Pit length 5.70 m, max. authorised loading 2500kg (wheel load max. 625kg), usable platform width. 2.50 - 2.70 m

### Standard passenger car

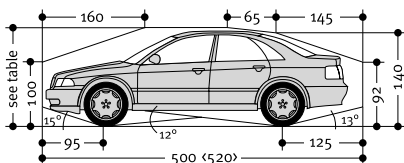

### Standard station wagon

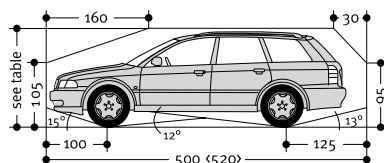

Standard passenger cars are vehicles without any sports options such as spoilers, low profile tyres etc.

# Load Plan (forces in kN)

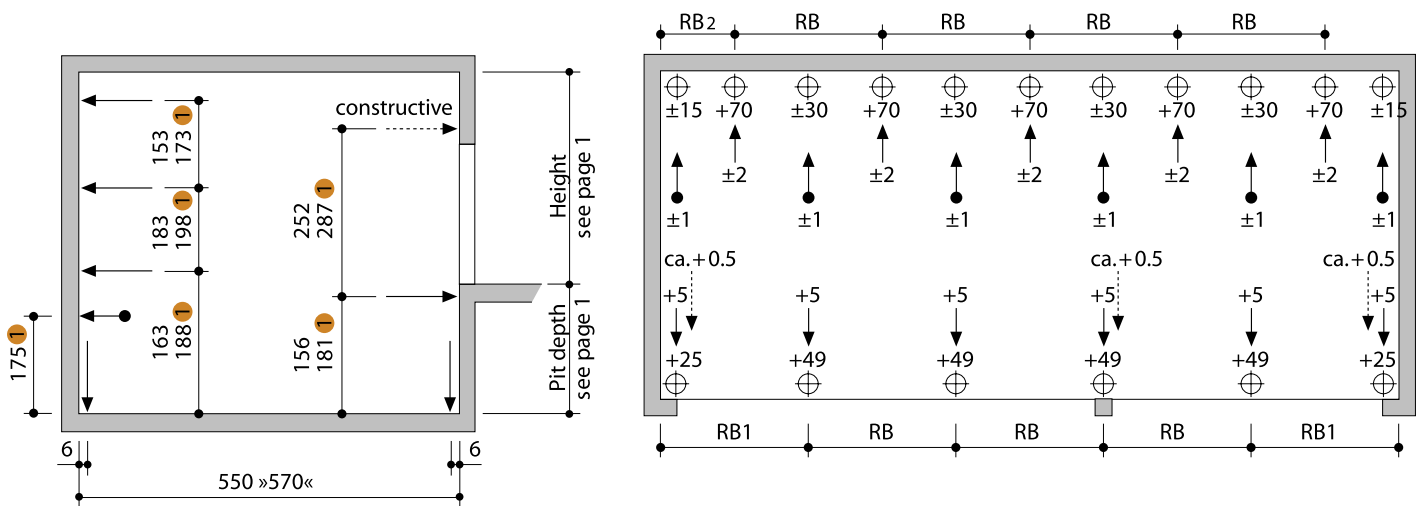

① = Dimensions for Exclusive Type

The system is dowelled to floor and walls. The drilling depth in the floor is approx. 15cm. The drilling depth in the walls is approx. 12cm. Floor and walls are to be made of concrete (grade of concrete min. C20/C25)!

Usable Platform

Width	RB	RB1	RB2
230*	250	260	135
240	260	270	140
250	270	280	145
260	280	290	150
270	290	300	155

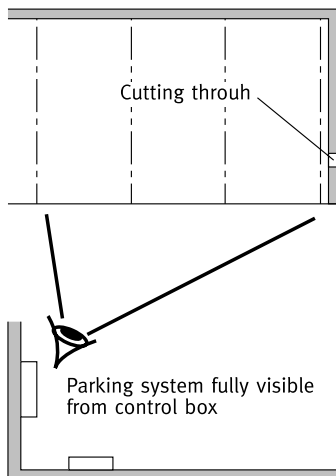

## Electrical Data

### Control Box

- Accessible from outside.
- Dimensions approx. 100 x 100 x 30.
- Suitable electrical supply 5 x 2,5mm<sup>2</sup>, (3 PH+N+PE) to control box with mains fuse 3 x 16A slow or over current cut-out 3 x 16 A trigger characteristic K, G or C
- Cutting through of wall from control box to parking system (contact the local agency of Klaus for clarification).
- Suitable electrical supply to the control box must be provided by the customer during installation. The functionality can be monitored on site by our fitters together with the electrician. If this cannot be done

during installation for some reason for which the customer is responsible, the customer must commission an electrician at their own expense and risk.

- In accordance with DIN EN 60204 (Safety of Machinery. Electrical Equipment), the system must be connected to a foundation earth.

A foundation earth connection must be installed at intervals of 10 m.

### Operating Panel

- easy-to-survey positioning (e.g. on column).
- protection against unauthorized use.
- may also be recessed in wall if required.

## Approach

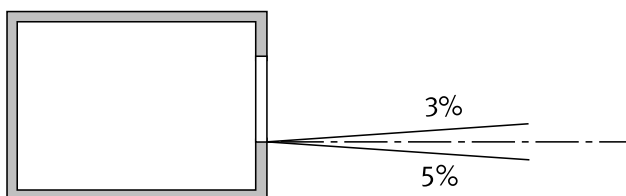

These illustrated maximum approach angles must NOT be exceeded. Incorrect approach angles will cause SERIOUS MANEOUVRING & POSITIONING PROBLEMS on the parking system for which Klaus accepts no responsibility.



Klaus Multiparking Systems Private Limited 5/3, Prashant Apartments, Erandwane, Pune-411004. India.

• Tel: +91-20-254 50378/254 58662 • Fax: +91-20-254 58663 • E-mail: info@klausmultiparking.in • www.multiparkingsystems.com