

PRODUCT DATA

Multibase D63 2000 kg ¹

Garage without door (basement garage)

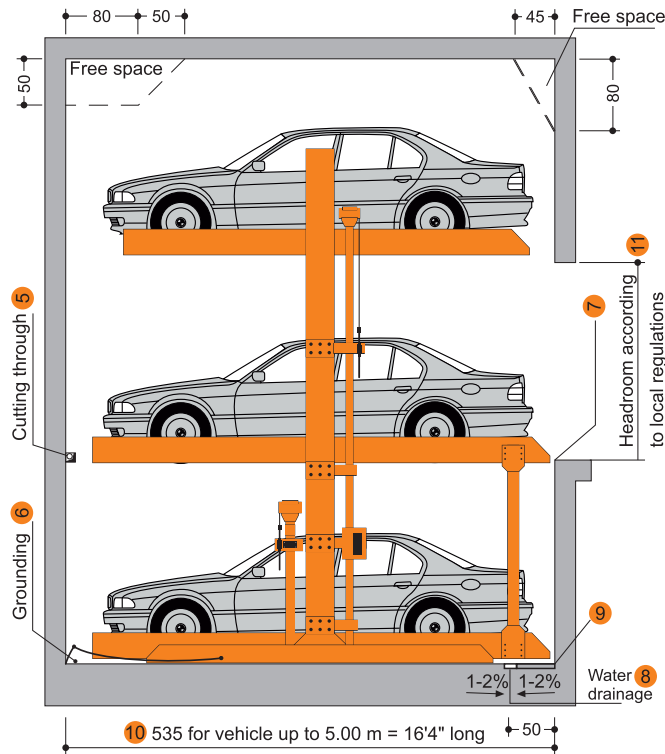

Dimensions

All space requirements are minimum finished dimensions.

Tolerances for space requirements $^{+3}_0$ ²

Dimensions in cm.

EB (single platform) = 3 vehicles

Suitable for

Standard passenger cars:
For PW 2.3 m. according to clearance and maximal surface load.

	Standard
Width	190 cm ³
Weight	max. 2000 kg
Wheel load	max. 500 kg

Clearance profile

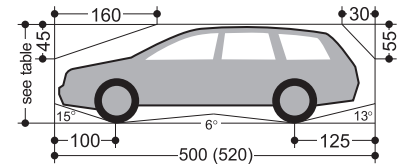

Model	Pit Depth	Car height upper	Car height middle	Car height lower
D63 - 175	175	150	150	150
D63 - 185	185	160	160	160
D63 - 195	195	170	170	170
D63 - 205	205	180	180	180
D63 - 215	215	190	190	190
D63 - 225	225	200	200	200

- Standard type
- To follow the minimum finished dimensions, make sure to consider the tolerances during construction.
- Car width for platform width 230 cm. If wider platforms are used, it is also possible to park wider cars.
- If a higher ceiling height is available, higher cars can be parked at top level platform.
- For dividing walls: cutting through 10 x 10 cm.
- Potential equalization from foundation grounding connection to system (provided by the customer).
- 10 cm wide yellow-black marking must be applied by the customer to the edge of the pit in the entry area to mark the danger zone (see "load plan" page 4).
- Slope with drainage channel and sump.
- At the transition section between pit floor and walls no hollow mouldings/cover are allowed. If hollow mouldings/cover are required, the systems must be designed smaller or the pits accordingly wider.
- For convenient use of your parking space and due to the fact that the cars keep becoming longer we recommend a pit length of 540 cm.
- Must be at least as high as the greatest car height + 5 cm.

Width dimensions for garage without door (basement garage)

Dividing walls

Single System (EB)

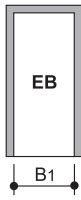

Usable platform width	B1
(220) 230	260
(230) 240	270
(240) 250	280

Double System (EB + EB)

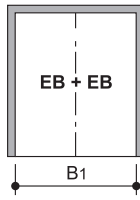

Usable platform width	B1
(220) 230 X 2	520
(230) 240 X 2	540
(240) 250 X 2	560

Triple System (EB + EB + EB)

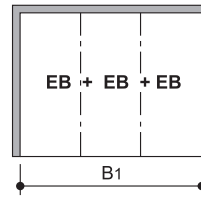

Usable platform width	B1
(220) 230 X 3	780
(230) 240 X 3	810
(240) 250 X 3	840

Driveway in accordance with local regulations

Columns in pit

Single System (EB)

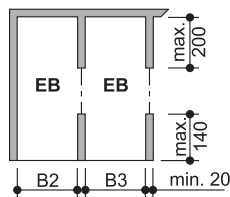

Usable platform width	B2	B3
(220) 230	255	250
(230) 240	265	260
(240) 250	275	270

Double system (EB + EB)

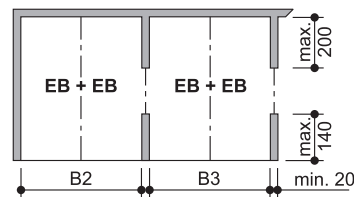

Usable platform width	B2	B3
(220) 230 X 2	510	505
(230) 240 X 2	530	525
(240) 250 X 2	550	545

Triple System (EB + EB + EB)

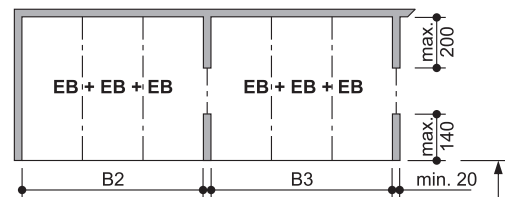

Usable platform width	B2	B3
(220) 230 X 3	755	750
(230) 240 X 3	785	780
(240) 250 X 3	815	810

Driveway in accordance with local regulations

Columns outside pit

Single System (EB)

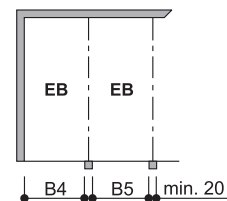

Usable platform width	B4	B5
(220) 230	250	240
(230) 240	260	250
(240) 250	270	260

Double System (EB + EB)

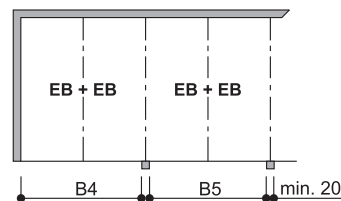

Usable platform width	B4	B5
(220) 230 X 2	490	480
(230) 240 X 2	510	500
(240) 250 X 2	530	520

Triple System (EB + EB + EB)

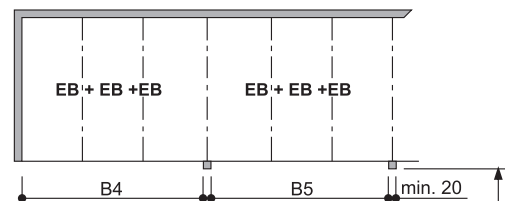

Usable platform width	B4	B5
(220) 230 X 3	730	740
(230) 240 X 3	760	760
(240) 250 X 3	790	780

Driveway in accordance with local regulations

! End parking spaces are generally more difficult to drive into. Therefore, we recommend our wider platforms for end parking spaces. Parking larger vehicles on standard width platforms may make getting into and out of the vehicle difficult. This depends on the type of the vehicle, approach and above all, on the driver's skill.

Function

All platforms at home position

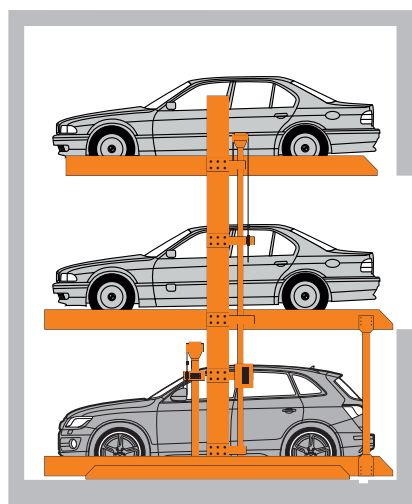

OG platform at entry level

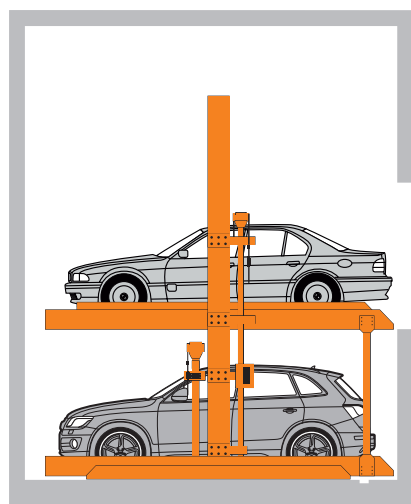

UG platform at entry level

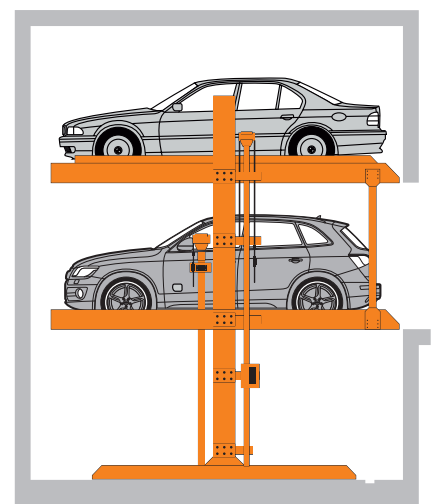

Page 1
- Section
- Dimensions
- Car data

Page 2
- Width dim. without door
- Function

Page 3
- Width dim. with door
- Approach

Page 4
- Load plan
- Installation

Page 5
- Electrical data
- Technical data
- To be performed by the customer

Page 6
- Description

Garage with door

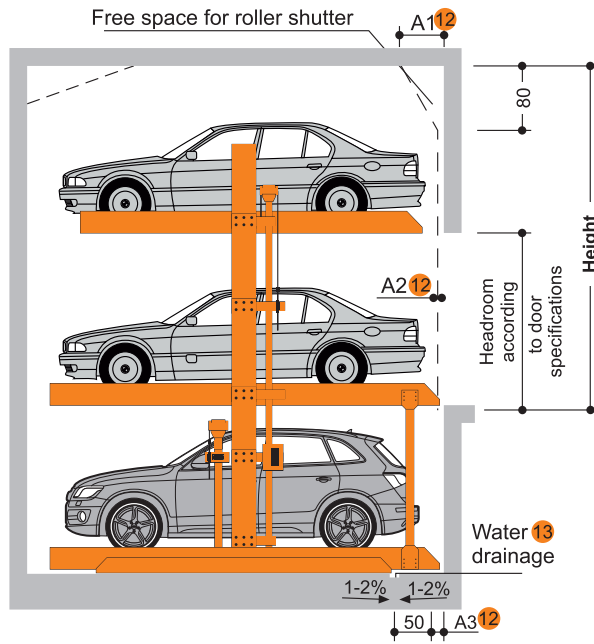

- 12** Dimensions A1, A2 and A3 must be coordinated with the door supplier (provided by the customer).
- 13** Slope with drainage channel and sump.
- 14** Seat-engaging surface (dimensions require coordination with door supplier.) All round door dimensions require coordination between door supplier and local agency of KLAUS Multiparking.

Width dimensions for garage with door

Single system (EB)

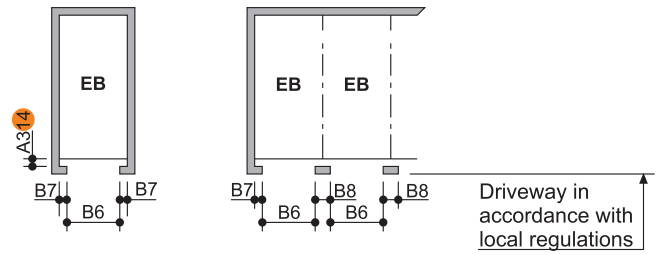

Usable platform width	Door entrance width	B6	B7	B8
(220) 230	230	15	30	
(230) 240	240	15	30	
(240) 250	250	15	30	

Double system (EB + EB)

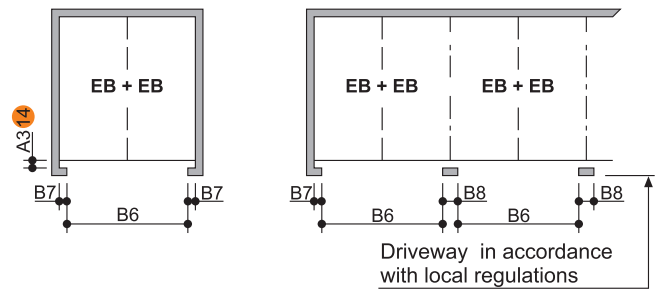

Usable platform width	Door entrance width	B6	B7	B8
(220) 230 X 2	490	20	40	
(230) 240 X 2	510	20	40	
(240) 250 X 2	530	20	40	

! End parking spaces are generally more difficult to drive into. Therefore, we recommend our wider platforms for end parking spaces. Parking larger vehicles on standard width platforms may make getting into and out of the vehicle difficult. This depends on the type of the vehicle, approach and above all, on the driver's skill.

Approach

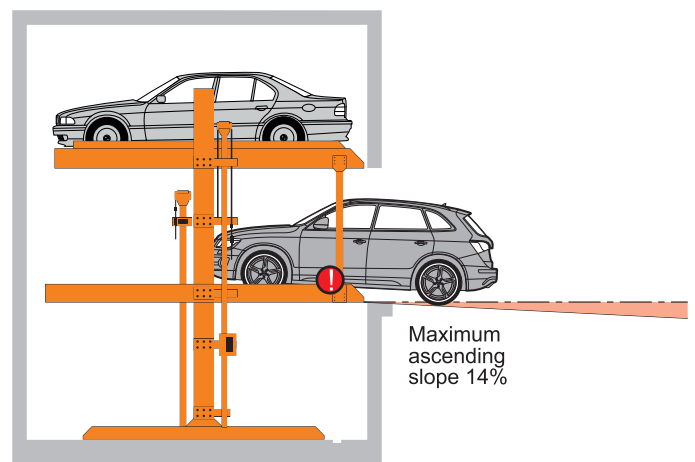
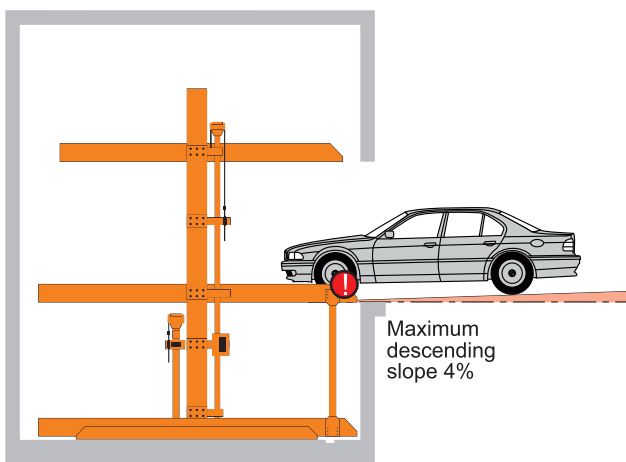

! The illustrated maximum approach angles must not be exceeded. Incorrect approach angles will cause serious maneuvering & positioning problems on the parking system for which the local agency of the KLAUS Multiparking accepts no responsibility.

Load plan

- Page 1
- Section
- Dimensions
- Car data
- Page 2
- Width dim. without door
- Function
- Page 3
- Width dim. with door
- Approach
- Page 4
- Load plan
- Installation
- Page 5
- Electrical data
- Technical data
- To be performed by the customer
- Page 6
- Description

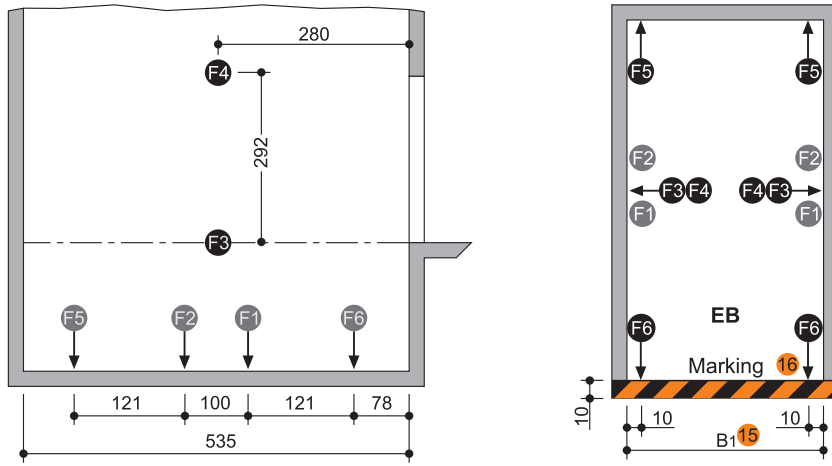

Platform load	F1	F2	F3	F4	F5	F6	17
EB 2000 kg	+76	+76	± 5	± 5	± 1	± 1.5	

! Units are doweled to the floor. Drilling depth: approx. 15 cm.
 Floor and walls below the drive-in level are to be made of concrete (quality minimum C20/25).
 The dimensions for the points of support are rounded values. If the exact position is required, please contact KLAUS Multiparking.

- 15 Dimension B1 see page 2
- 16 Colors used in this illustration are representative
- 17 All forces in kN (Static Loads)

Installation data - Free space for longitudinal and vertical ducts (e.g. ventilation)

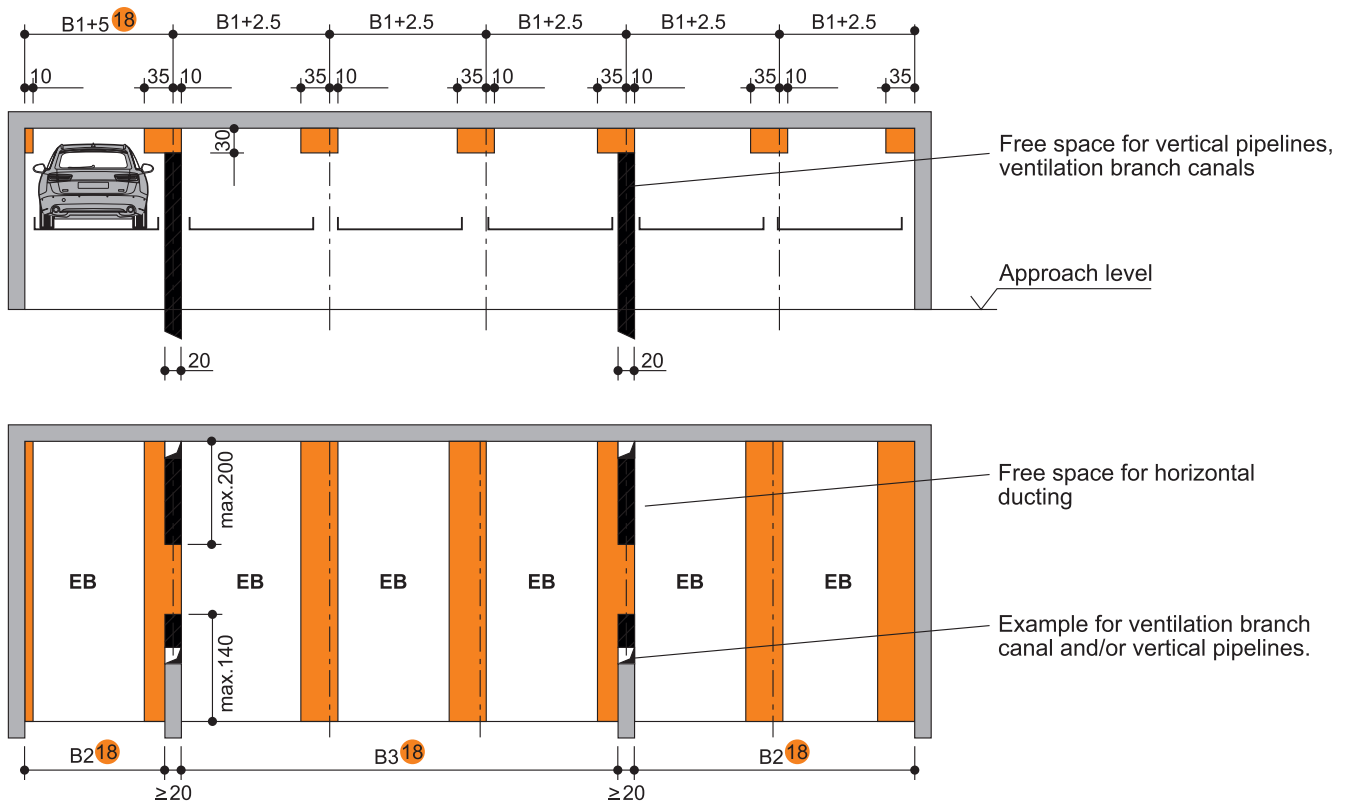

! Free space only applicable if vehicle is parked forward = FRONT FIRST and driver's door on the right side.

- 18 Dimensions B1, B2 and B3 see page 2.

Electrical installation

- Page 1
- Section
- Dimensions
- Car data
- Page 2
- Width dim.
without door
- Function
- Page 3
- Width dim.
with door
- Approach
- Page 4
- Load plan
- Installation
- Page 5
- Electrical data
- Technical data
- To be performed by the customer
- Page 6
- Description

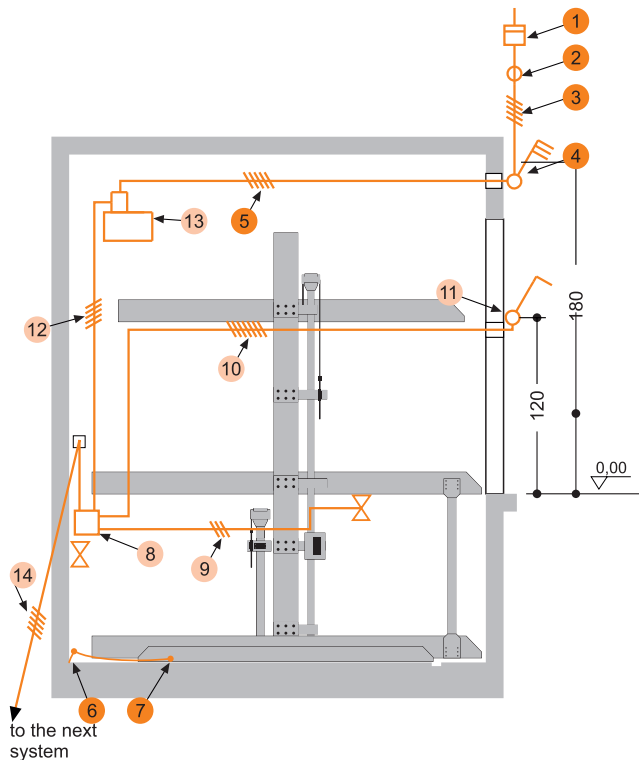

Electrical data (to be performed by the customer)

No.	Quantity	Description	Position	Frequency
1	1	Electricity meter	In the supply line	
2	1	Main power point: 4 pole RCBO (or MCB + ELCB), 25 Amp IDN (sensitivity/leakage current) 100 mA	In the supply line	1 per unit
3	1	Supply line 5 x 4.0mm ² , copper (3PH + N + PE) with marked wire and protective conductor	To main switch	1 per unit
4	1	N.A.		
5	1	Supply line 5 x 4.0mm ² (3PH + N + PE) with marked wire and protective conductor	From main switch to unit	1 per unit
6	every 10 m	Foundation earth connector	Corner pit floor	
7	1	Equipotential bonding from foundation earth connector to the system		1 per system

Electrical data (included in delivery of KLAUS Multiparking)

No.	Description
8	Terminal box
9	Control line 3 x 0.75 mm ² with marked wire and protective conductor
10	Control line 8 x 1.0 mm ² with marked wire and protective conductor
11	Operating device
12	Control line 5 x 1.5 mm ² with marked wire and protective conductor
13	Hydraulic unit 3.0 kW, three-phase current, 415 V / 50 Hz
14	Control line 5 x 1.5 mm ² with marked wire and protective conductor

Technical data

Field of application

Generally parking system is suitable for the same car length for which the wheelstop is adjusted, at the time of installation. In case different car is to be parked, wheelstop adjustment confirmation from KLAUS Multiparking shall be required.

Care

To avoid damages resulting from corrosion, make sure to follow our cleaning and care instructions and to provide good ventilation of your garage.

Railings

If the permissible drop opening is exceeded, railings are to be provided. If there are traffic routes next to or behind the installations, railings must be installed by the customer. Railings must also be in place during installation.

Environmental conditions

Environmental conditions for the area of multiparking systems: Temperature range 5° C to +40° C. Maximum outside temperature of +45° C.

If the local circumstances differ from the above, please contact KLAUS Multiparking.

To be performed by the customer

Safely fences

Any constraints that may be necessary to provide protection for the park pits for pathways directly in front, next to or behind the unit, before starting installation of parking systems.

Numbering of parking spaces

Consecutive numbering of parking spaces.

Building services

Any required lighting, ventilation, fire extinguishing and fire alarm systems as well as clarification and compliance with the relevant regulatory requirements.

Drainage

For the front area of the pit we recommend a drainage channel, which you connect to a floor drain system or sump (50 x 50 x 20 cm). The drainage channel may be inclined to the side, however not the pit for itself (longitudinal incline is allowable). For reasons of environmental protection we recommend to paint the pit floor, and to provide oil and petrol separators in the connections to the public sewage systems.

Strip footings

If due to structural condition strip footings must be effected, the customer shall be provided an accessible platform reaching to the top of the said strip footings to enable and facilitate the mounting work.

Marking

A warning that identifies this danger area must be placed in the entrance area. This must be done for systems with a pit (platforms within the pit) 10 cm from the edge of the pit.

Wall cuttings

Any necessary wall cuttings according to page 1.

Electrical supply to the main switch/foundation earth connector

Suitable electrical supply to the control box must be provided by the customer. The functionality can be monitored on site by our fitters together with the electrician. If this cannot be done during installation for some reason for which the customer is responsible, the customer must commission an electrician at his own expense and risk.

Safety of machinery, electrical equipment, grounding of the steel structure is necessary, provided by the customer (distance between grounding max. 10 m).

Description Single System (EB) and Double System (EB + EB)

General description

KLAUS Multiparking system providing dependent parking spaces for 3 cars (EB), one on top of the other each.

Dimensions are in accordance with the underlying dimensions of parking pit, height and width.

The parking bays are accessed horizontally (installation deviation $\pm 1\%$).

Vehicles are positioned on each parking space using wheel stop on the left side (adjust according to operating instructions).

The user is responsible for positioning the vehicle.

Operation via operating device with hold-to-run-device using master keys.

The operating elements are usually mounted either in front of the column or on the outside of the door frame.

Operating instructions are attached to each operator's stand.

For safety reasons it is recommended to install safety doors at the entrance of the system.

For garages with doors at the front of the parking system the special dimensional requirements have to be taken into account.

Multiparking system consists of

- 2 steel pillars with bases that are mounted on the floor
- 3 sliding platforms (mounted to the steel pillars with sliding bearings)
- 3 platform
- 2 mechanic synchronization control system (to ensure synchronous operation on the hydraulic cylinders while lowering and lifting the platform)
- 3 hydraulic cylinders
- 2 rigid supports (connect the platforms)
- Welded hydraulic lines up to installed vent valve
- Dowels, screws, connecting elements, bolts, etc
- The platforms and parking spaces are end-to-end accessible for parking.

Platforms consists of

- Platform base sections
- Adjustable wheel stops
- Access plates
- Side members
- Cross members
- Screws, nuts, washers, distance tubes, etc.

Hydraulic system consists of

- Hydraulic cylinder
- Solenoid valve
- Safety valve
- Hydraulic pipes
- Screwed joints
- high-pressure hoses
- Installation material

Electric system consists of

- Operating device (Emergency Stop, lock, 1 master key per parking space)
- Terminal box at wall valve
- Infrared sensors

Hydraulic unit consists of

- Hydraulic power unit
- Hydraulic oil reservoir
- Oil filling
- Internal geared wheel pump
- Pump holder
- 3-phase-AC-motor
- Contactor (with thermal overcurrent relay and control fuse)
- Pressure gauge
- Pressure relief valve
- Hydraulic hoses (which reduce noise transmission onto the hydraulic pipe)

We reserve the right to change these specifications without prior notice.

KLAUS Multiparking reserves the right in the course of the technical progress to use newer or other technologies, system, processes, procedures or standards in the fulfillment of their obligations other than those originally offered.

Page 1
- Section
- Dimensions
- Car data

Page 2
- Width dim.
without door
- Function

Page 3
- Width dim.
with door
- Approach

Page 4
- Load plan
- Installation

Page 5
- Electrical data
- Technical data
- To be performed by the customer

Page 6
- Description